



10711 IH 35 North
San Antonio, Texas 78233
Phone: 210.653.2500

sales@alamorefrigeration.com
<http://www.alamorefrigeration.com>

Models:
CDC Family

Description:
Deluxe Dipping Cabinet Refrigerators and Freezers



Manufactured By:

Standard Features of Alamo Flat Top Refrigerators And Freezers

► Bottom Mounted Compressor

Heavy-Duty compressor is bottom mounted for easy cleaning and maintenance.

► Dual Thermostat

Allows for Freezer or Cooler modes for a use with a wider variety of product.

* Temperature Range: 0 F - 38 F

► Versatile Caster

Our pre- installed casters allows easy set up and mobility for floor cleaning. Additional caster lock function ensures unit placements and stability, preventing damage caused from moving.

► Door Lock

Safety door lock provides security for high priced inventory.

► 5/16 inch Tempered Glass Sneeze Rail

Helps prevent outside contaminant with servicing or storing.

► Sneeze Rail Lighting (Optional)

L.E.D. light conveniently allows visibility for working in dark rooms and areas.

► Ideal Use with:

Dipping Ice Cream, Gelato and Italian Ices

► Available Options

- Gelato basket tub holders
- Dip well
- 3 gallon tub holders
- Can skirts
- Clear or white lid covers available.





Deluxe Dipping Cabinet Refrigerators and Freezers

Deluxe Dipping Cabinet Refrigerators And Freezers				
Model	CDC-30	CDC-41	CDC-52	CDC-61
Voltage	115V/60Hz	115V/60Hz	115V/60Hz	115V/60Hz
Interior Volume	8.6 cu. ft.	10.3 cu. ft.	13.6 cu. ft.	14.1 cu. ft.
Temperature	0°F to 38°F	0°F to 38°F	0°F to 38°F	0°F to 38°F
Temperature Control	Manual	Manual	Manual	Manual
Refrigerant	Refrigerator: R-134 / Freezer: 404A	Refrigerator: R-134 / Freezer: 404A	Refrigerator: R-134 / Freezer: 404A	Refrigerator: R-134 / Freezer: 404A
Dimensions (in.)	31.5 L x 24.80 W x 36.22 H	39.37 L x 24.80 W x 36.22 H	49.61 L x 24.80 W x 36.22 H	59.06 L x 24.21 W x 36.61 H
Net Weight (lb/kg)	115 lbs.	159 lbs.	190 lbs.	214 lbs.
Included	(2) 3 Gallon Tub Holder Basket(s) (2) Can Skirt(s) (2) White Lid Cover(s) Lock & Key Side Mounted Thermometer	(3) 3 Gallon Tub Holder Basket(s) (3) Can Skirt(s) (3) White Lid Cover(s) Lock & Key Side Mounted Thermometer	(4) 3 Gallon Tub Holder Basket(s) (4) Can Skirt(s) (4) White Lid Cover(s) Lock & Key Side Mounted Thermometer	(5) 3 Gallon Tub Holder Basket(s) (5) Can Skirt(s) (5) White Lid Cover(s) Lock & Key Side Mounted Thermometer

Deluxe Dipping Cabinet Refrigerators And Freezers	
Model	CDC-70
Voltage	115V/60Hz
Interior Volume	18.5 cu. ft.
Temperature	0°F to 38°F
Temperature Control	Manual
Refrigerant	Refrigerator: R-134 / Freezer: 404A
Dimensions (in.)	67.75 L x 24.21 W x 36.61 H
Net Weight (lb/kg)	243 lbs.
Included	(6) 3 Gallon Tub Holder Basket(s) (6) Can Skirt(s) (6) White Lid Cover(s) Lock & Key Side Mounted Thermometer

- #280567 - 3 Gallon Baskets
- #280496 - Skirts for Baskets
- #280378 - Small Gelato Baskets
- #280374 - Large Gelato Baskets
- #715990 - Dipper Well
- #850099 - Lock w/ 2 Keys
- #360077 - Dual T-Stat
- #CC3G - Can Cover Clear



*Clear Can Cover Shown

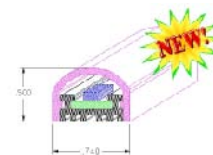
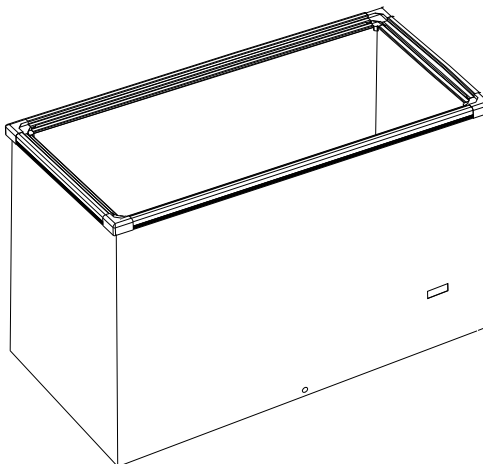
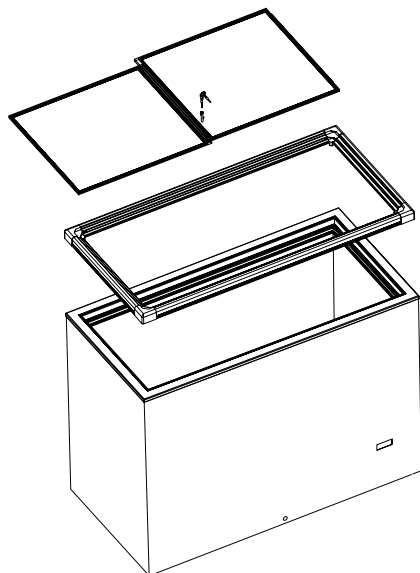

L.E.D. Lighting
CLEAR & FROSTED AVAILABLE



FROSTED



CLEAR

Note: Continuous product development may necessitate specification changes and design
Warranty 1 Year Parts and Labor; 5 Years Compressor

Alamo Refrigeration, LP

10711 IH 35 N • San Antonio, Texas 78233 • PH: 210.653.2500 • Fax:210.653.2504

sales@alamorefrigeration.com • www.alamorefrigeration.com